

CMOS Analog Switches

Features

- Analog Signal Range: $\pm 15\text{ V}$
- Fast Switching— t_{ON} : 150 ns
- Low On-Resistance— $r_{DS(on)}$: 30 Ω
- Single Supply Operation
- Latch-up Proof
- CMOS Compatible

Benefits

- Full Rail-to-Rail Analog Signal Range
- Low Signal Error
- Low Power Dissipation

Applications

- Low Level Switching Circuits
- Programmable Gain Amplifiers
- Portable and Battery Powered Systems

Description

The DG300A-DG303A family of monolithic CMOS switches feature three switch configuration options (SPST, SPDT, and DPST) for precision applications in communications, instrumentation and process control, where low leakage switching combined with low power consumption are required.

In the on condition the switches conduct equally well in both directions (with no offset voltage) and minimize error conditions with their low on-resistance.

Designed on the Siliconix PLUS-40 CMOS process, these switches are latch-up proof, and are designed to block up to 30 V peak-to-peak when off. An epitaxial layer prevents latchup.

Featuring low power consumption (3.5 mW typ) these switches are ideal for battery powered applications, without sacrificing switching speed. Designed for break-before-make switching action, these devices are CMOS and quasi TTL compatible. Single supply operation is allowed by connecting the V- rail to 0 V.

Functional Block Diagram and Pin Configuration

DG300A

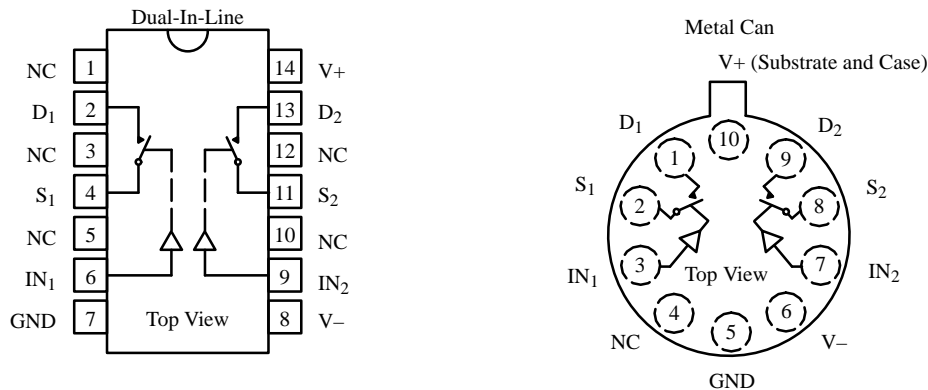

Ordering Information – DG300A

Temp Range	Package	Part Number
0 to 70°C	14-Pin Plastic DIP	DG300ACJ
-25 to 85°C	14-Pin CerDIP	DG300ABK
	10-Pin Metal Can	DG300ABA
-55 to 125°C	14-Pin CerDIP	DG300AAK
		DG300AAK/883
		JM38510/11601BCA
	14-Pin Sidebrazed	JM38510/11601BCC
	10-Pin Metal Can	DG300AAA/883
JM38510/11601BIA		

Truth Table

Logic	Switch
0	OFF
1	ON

Logic "0" $\leq 0.8\text{ V}$
 Logic "1" $\geq 4\text{ V}$
 Switches Shown for Logic "0" Input

Updates to this data sheet may be obtained via facsimile by calling Siliconix FaxBack, 1-408-970-5600. Please request FaxBack document #70044.

Functional Block Diagram and Pin Configuration (Cont'd)

DG301A

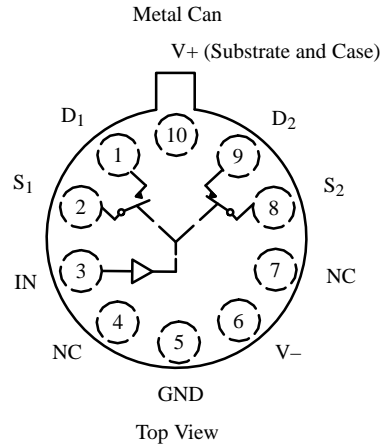
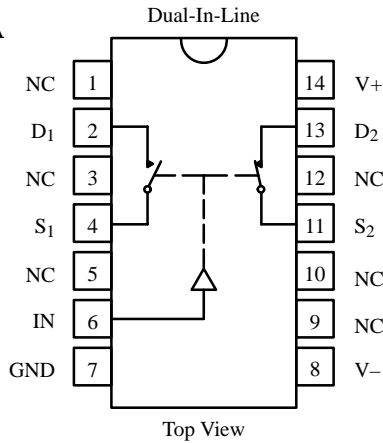

Ordering Information – DG301A

Temp Range	Package	Part Number
0 to 70°C	14-Pin Plastic DIP	DG301ACJ
-25 to 85°C	14-Pin CerDIP	DG301ABK
	10-Pin Metal Can	DG301ABA
-55 to 125°C	14-Pin CerDIP	DG301AAK/883
		JM38510/11602BCA
	14-Pin Sidebrazed	JM38510/11602BCC
	10-Pin Metal Can	DG301AAA
		DG301AAA/883
		JM38510/11602BIA

Truth Table

Logic	SW ₁	SW ₂
0	OFF	ON
1	ON	OFF

Logic "0" ≤ 0.8 V
Logic "1" ≥ 4 V

Switches Shown for Logic "0" Input

DG302A

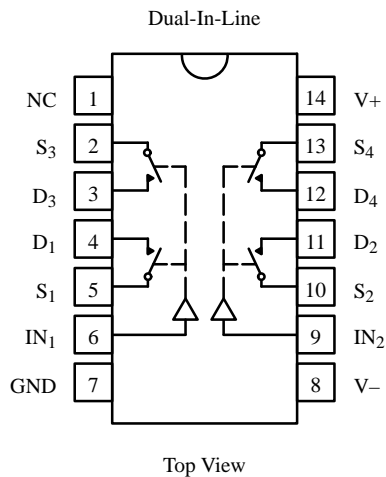

Truth Table

Logic	Switch
0	OFF
1	ON

Logic "0" ≤ 0.8 V
Logic "1" ≥ 4 V

Switches Shown for Logic "0" Input

Ordering Information – DG302A

Temp Range	Package	Part Number
0 to 70°C	14-Pin Plastic DIP	DG302ACJ
-55 to 125°C	14-Pin CerDIP	DG302AAK
		DG302AAK/883
		JM38510/11603BCA
	14-Pin Sidebrazed	JM38510/11603BCC

Functional Block Diagram and Pin Configuration (Cont'd)

DG303A

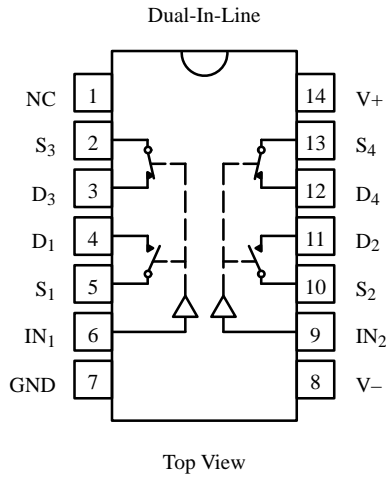

Truth Table

Logic	SW ₁ , SW ₂	SW ₃ , SW ₄
0	OFF	ON
1	ON	OFF

Logic "0" ≤ 0.8 V
Logic "1" ≥ 4 V

Switches Shown for Logic "0" Input

Ordering Information – DG303A

Temp Range	Package	Part Number
0 to 70°C	14-Pin Plastic DIP	DG303ACJ
-25 to 85°C	14-Pin CerDIP	DG303ABK
-45 to 85°C	14-SOIC	DG303ADY
-55 to 125°C	14-Pin CerDIP	DG303AAK
		DG303AAK/883
		JM38510/11604BCA
	14-Pin Sidebrazed	JM38510/11604BCC

Absolute Maximum Ratings

Voltages Referenced to V-

V+ 44 V

GND 25 V

Digital Inputs^a, V_S, V_D (V-) -2 V to (V+) +2V or 30 mA, whichever occurs first

Current, Any Terminal 30 mA

Continuous Current, S or D
(Pulsed at 1 ms, 10% duty cycle max) 100 mA

Storage Temperature (A & B Suffix) -65 to 150°C
(C Suffix) -65 to 125°C

Power Dissipation^b

14-Pin Plastic DIP^c 470 mW

14-Pin CerDIP^d 825 mW

10-Pin Metal Can^e 450 mW

Notes:

- a. Signals on S_X, D_X, or IN_X exceeding V+ or V- will be clamped by internal diodes. Limit forward diode current to maximum current ratings.
- b. All leads welded or soldered to PC Board.
- c. Derate 6.5 mW/°C above 25°C
- d. Derate 11 mW/°C above 75°C
- e. Derate 6 mW/°C above 75°C

Specifications^a

Parameter	Symbol	Conditions Unless Otherwise Specified $V_+ = 15\text{ V}$, $V_- = -15\text{ V}$ $V_{IN} = 0.8\text{ V}$ or $V_{IN} = 4\text{ V}^f$	Temp ^b	Typ ^c	A Suffix -55 to 125°C		B, C Suffix		Unit
					Min ^d	Max ^d	Min ^d	Max ^d	
Analog Switch									
Analog Signal Range ^e	V_{ANALOG}		Full		-15	15	-15	15	V
Drain-Source On-Resistance	$r_{DS(on)}$	$V_D = \pm 10\text{ V}$, $I_S = -10\text{ mA}$	Room Full	30		50 75		50 75	Ω
Source Off Leakage Current	$I_{S(off)}$	$V_S = \pm 14\text{ V}$, $V_D = \mp 14\text{ V}$	Room Hot	± 0.1	-1 -100	1 100	-5 -100	5 100	nA
Drain Off Leakage Current	$I_{D(off)}$		Room Hot	± 0.1	-1 -100	1 100	-5 -100	5 100	
Drain On Leakage Current	$I_{D(on)}$	$V_D = V_S = \pm 14\text{ V}$	Room Hot	± 0.1	-1 -100	1 100	-5 -100	5 100	
Digital Control									
Input Current with Input Voltage High	I_{INH}	$V_{IN} = 5\text{ V}$	Room Full	-0.00 1	-1 -1		-1		μA
		$V_{IN} = 15\text{ V}$	Room Full	0.001		1 1		1	
Input Current with Input Voltage Low	I_{INL}	$V_{IN} = 0\text{ V}$	Room Full	-0.00 1	-1 -1		-1		
Dynamic Characteristics									
Turn-On Time	t_{ON}	See Figure 2	Room	150		300			ns
Turn-Off Time	t_{OFF}		Room	130		250			
Break-Before-Make Time	t_{OPEN}	DG301A/303A Only, Figure 3	Room	50					
Charge Injection	Q	$C_L = 1\text{ nF}$, $R_{gen} = 0\text{ }\Omega$ $V_{gen} = 0\text{ V}$, Figure 4	Room	8					pC
Source-Off Capacitance	$C_{S(off)}$	$V_S, V_D = 0\text{ V}$, $f = 1\text{ MHz}$	Room	14					pF
Drain-Off Capacitance	$C_{D(off)}$		Room	14					
Channel-On Capacitance	$C_{D(on)}$		Room	40					
Input Capacitance	C_{in}	$f = 1\text{ MHz}$	$V_{IN} = 0\text{ V}$	Room	6				
			$V_{IN} = 15\text{ V}$	Room	7				
Off-Isolation	OIRR	$V_{IN} = 0\text{ V}$, $R_L = 1\text{ k}\Omega$ $V_S = 1\text{ V}_{rms}$, $f = 500\text{ kHz}$	Room	62					dB
Crosstalk (Channel-to-Channel)	X_{TALK}		Room	74					
Power Supplies									
Positive Supply Current	I_+	$V_{IN} = 4\text{ V}$ (One Input) All Others = 0 V	Room Full	0.23		0.5 1		1	mA
Negative Supply Current	I_-		Room Full	-0.00 1	-10 -100		-100		μA
Positive Supply Current	I_+	$V_{IN} = 0.8\text{ V}$ (All Inputs)	Room Full	0.001		10 100		100	
Negative Supply Current	I_-		Room Full	-0.00 1	-10 -100		-100		

Notes:

- Refer to PROCESS OPTION FLOWCHART (Section 5 of the 1994 Data Book or FaxBack number 7103).
- Room = 25°C, Full = as determined by the operating temperature suffix.
- Typical values are for DESIGN AID ONLY, not guaranteed nor subject to production testing.
- The algebraic convention whereby the most negative value is a minimum and the most positive a maximum, is used in this data sheet.
- Guaranteed by design, not subject to production test.
- V_{IN} = input voltage to perform proper function.

Typical Characteristics

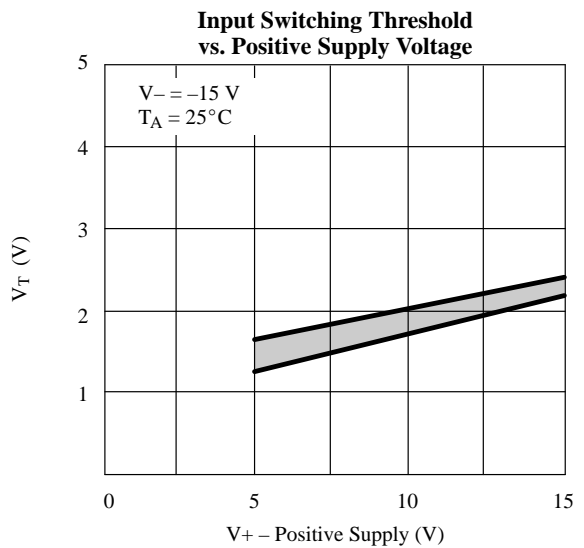
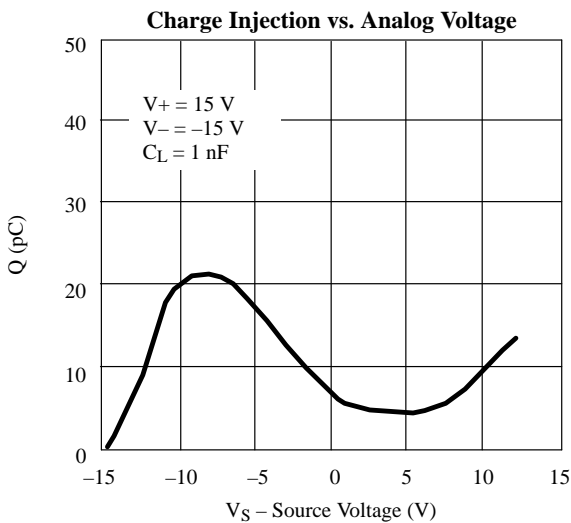
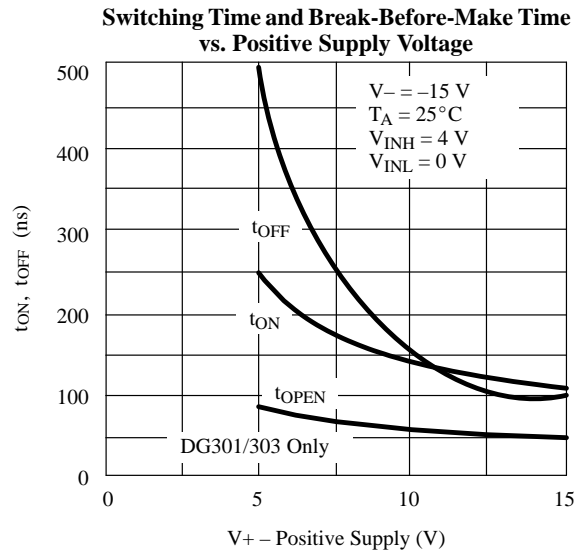
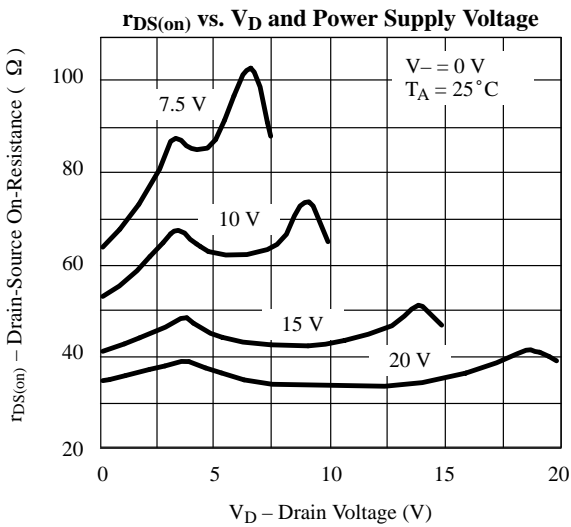
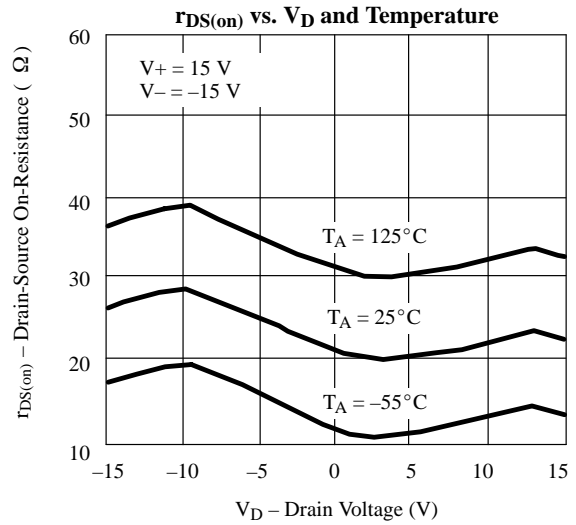
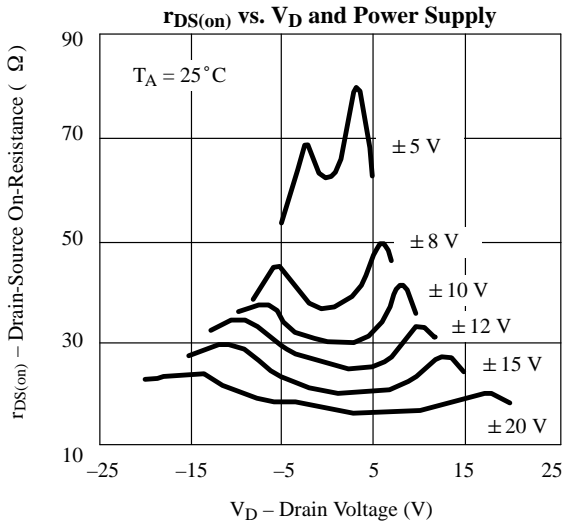

Typical Characteristics (Cont'd)

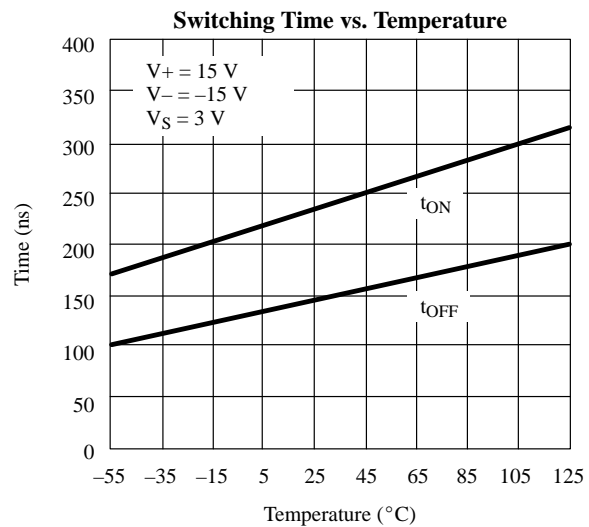
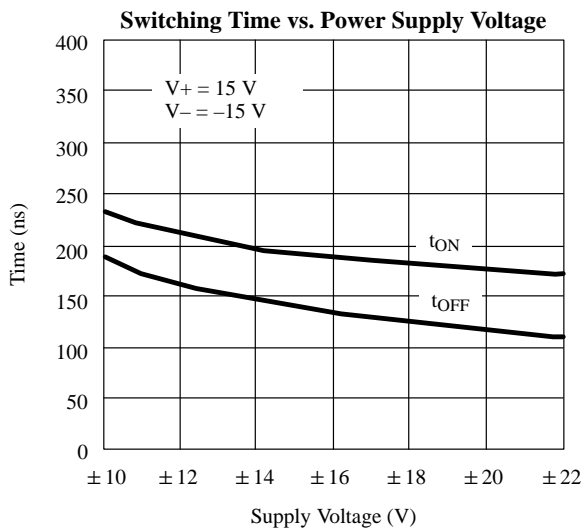
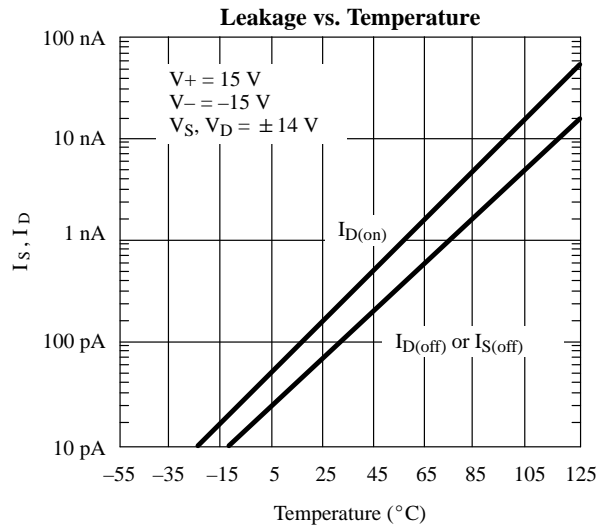
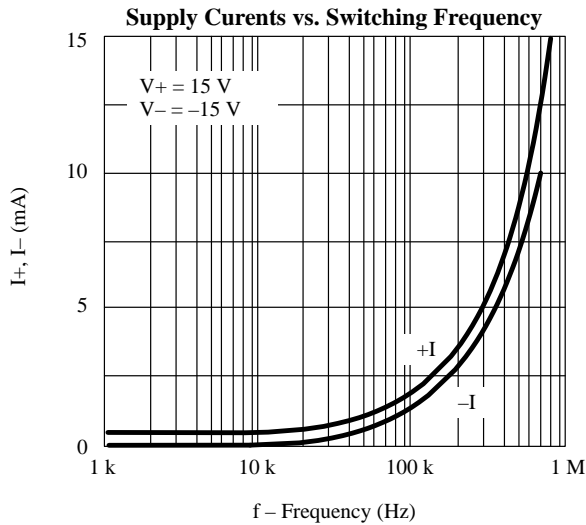
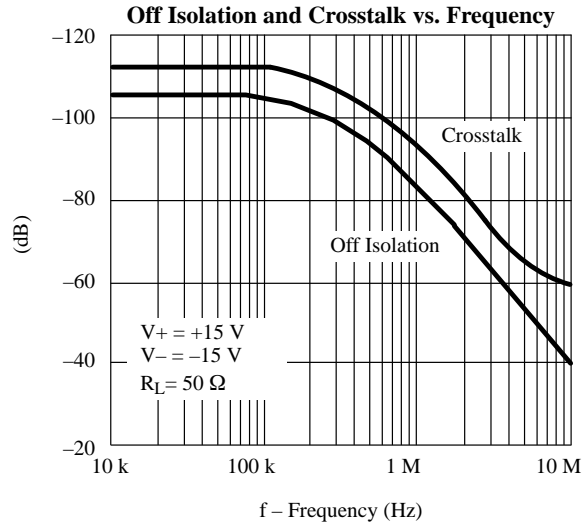
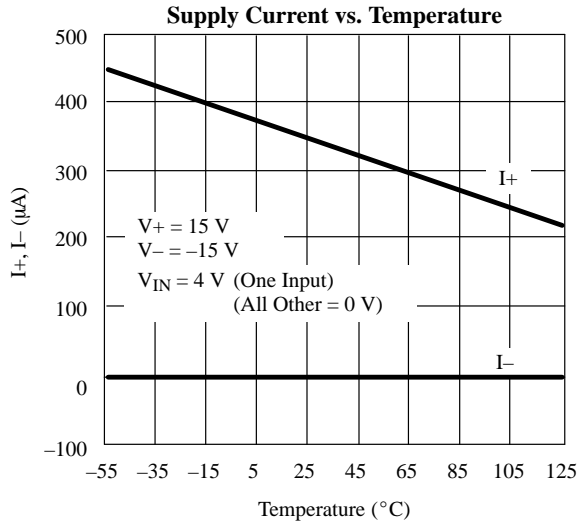

Schematic Diagram (Typical Channel)

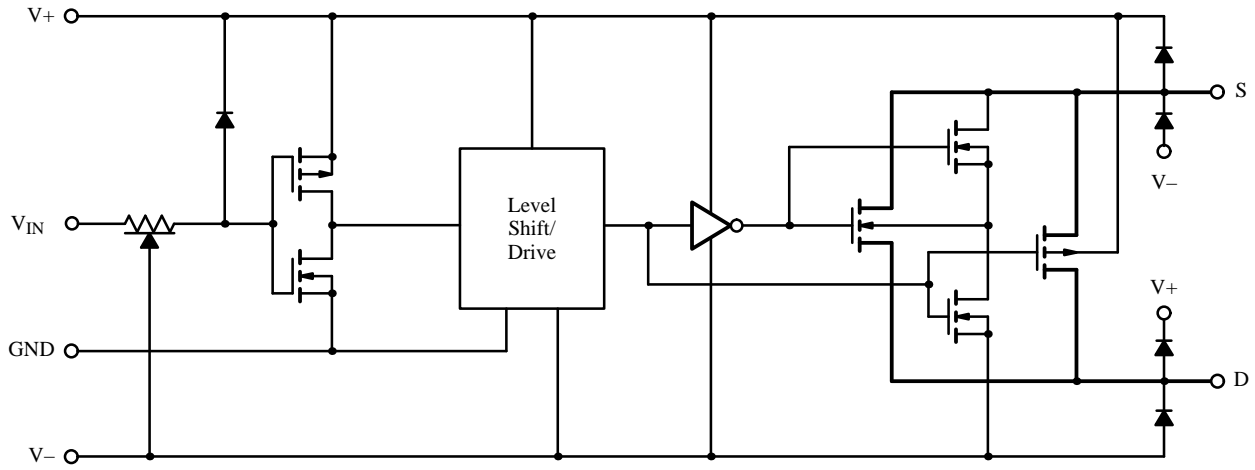
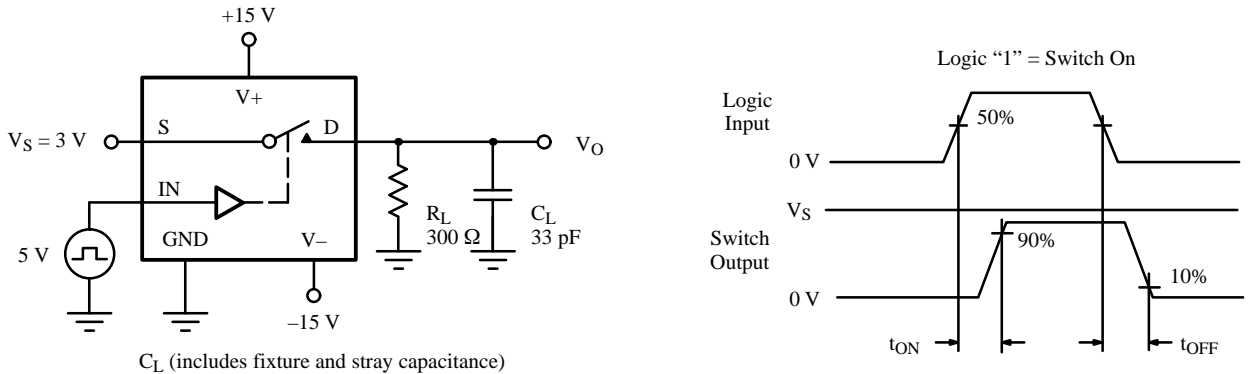

Figure 1.

Test Circuits



C_L (includes fixture and stray capacitance)

$$V_O = V_S \frac{R_L}{R_L + r_{DS(on)}}$$

Figure 2. Switching Time

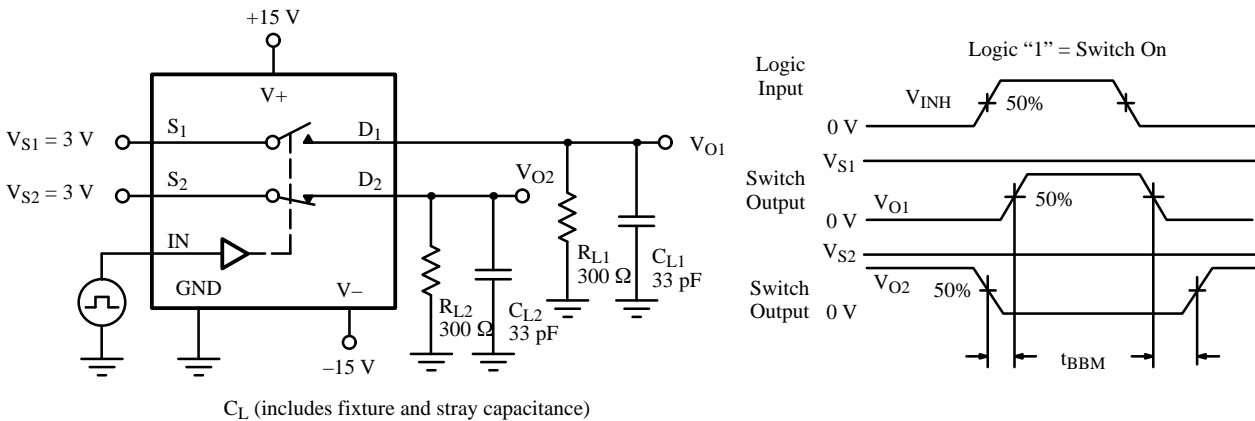

C_L (includes fixture and stray capacitance)

Figure 3. Break-Before-Make SPDT (DG301A, DG303A)

Test Circuits (Cont'd)

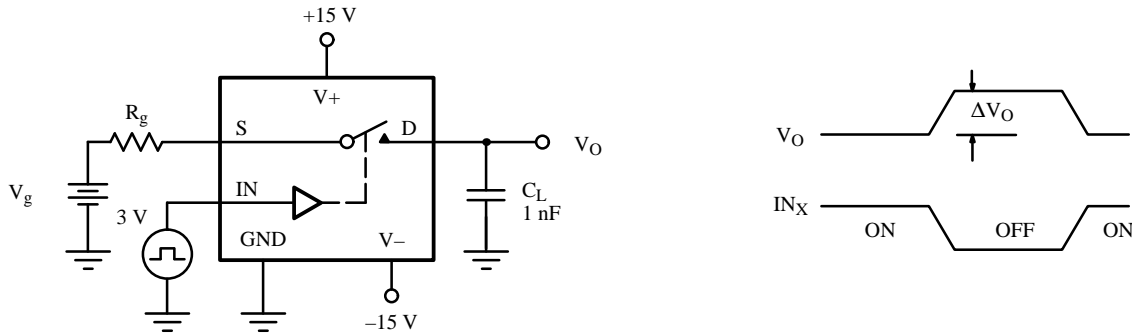

Figure 4. Charge Injection

Application Hints^a

V+ Positive Supply Voltage (V)	V- Negative Supply Voltage (V)	GND Voltage (V)	V _{IN} Logic Input Voltage V _{INH(min)} /V _{INL(max)} (V)	V _S or V _D Analog Voltage Range (V)
15	-15	0	4/0.8	-15 to 15
20	-20	0	4/0.8	-20 to 20
15	0	0	4/0.8	0 to 15

Note:

a. Application Hints are for DESIGN AID ONLY, not guaranteed and not subject to production testing.

Applications

The DG300A series of analog switches will switch positive analog signals while using a single positive supply. This facilitates their use in applications where only one supply is available. The trade-offs of using single supplies are: 1) Increased $r_{DS(on)}$; 2) slower

switching speed. The analog voltage should not go above or below the supply voltages which in single operation are V+ and 0 V. (See Input Switching Threshold vs. Positive Supply Voltage Curve.)

Applications (Cont'd)

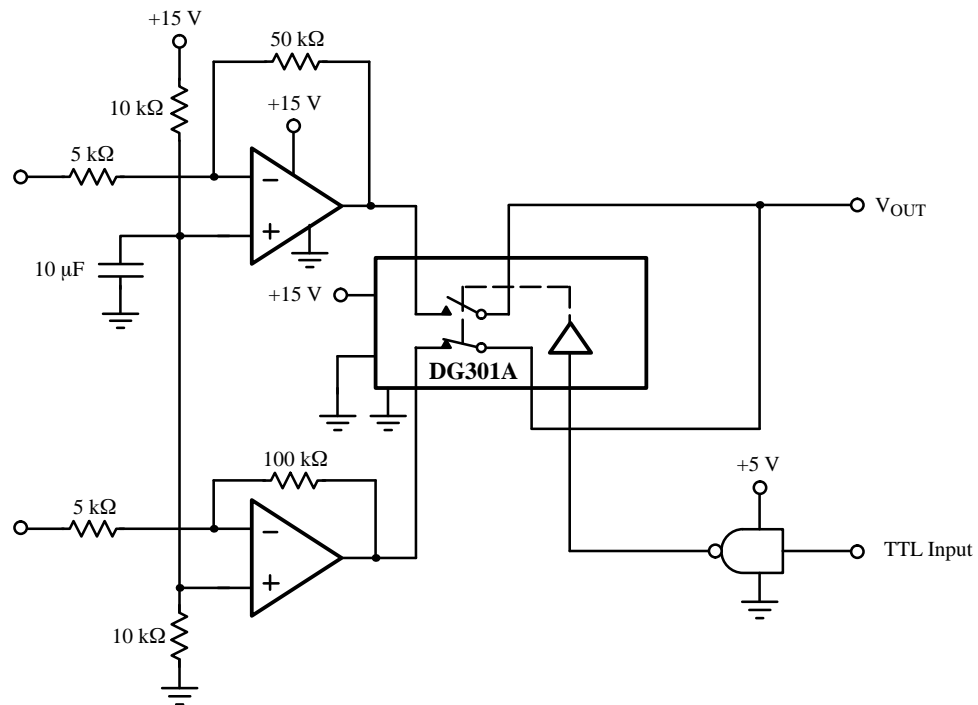

Figure 5. Single Supply Op Amp Switching

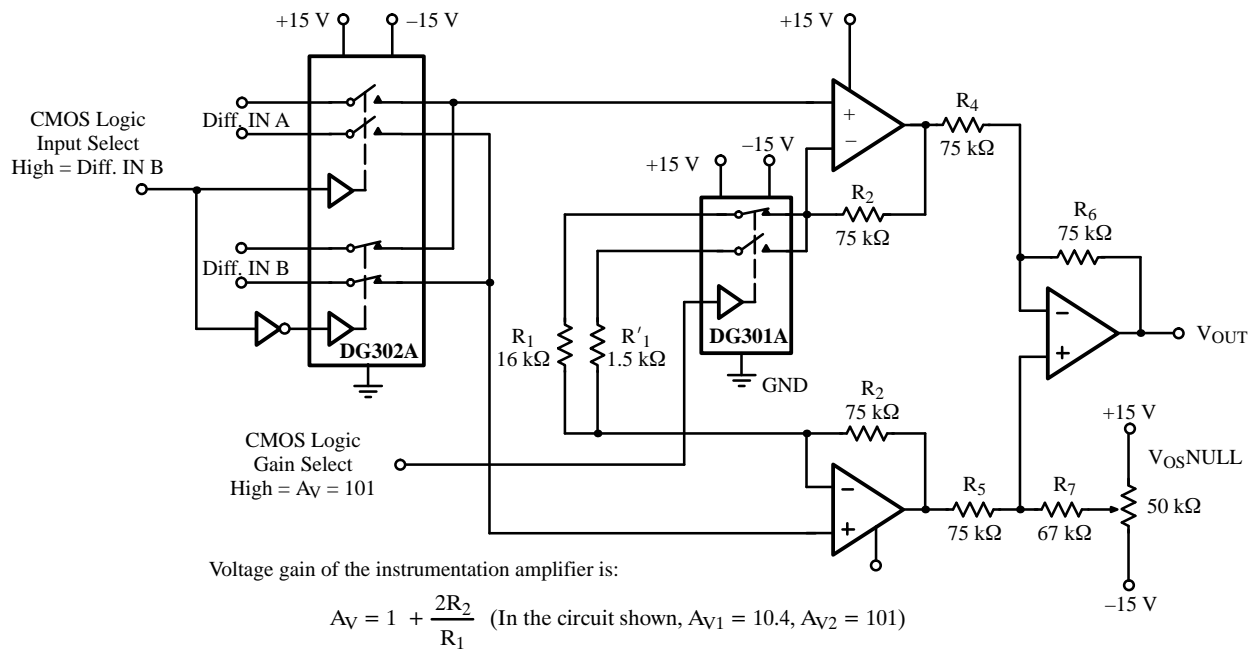

Figure 6. Low Power Instrumentation Amplifier with Digitally Selectable Inputs and Gain